

General Specifications

230 FEET BOOM AND JIB

75 TON

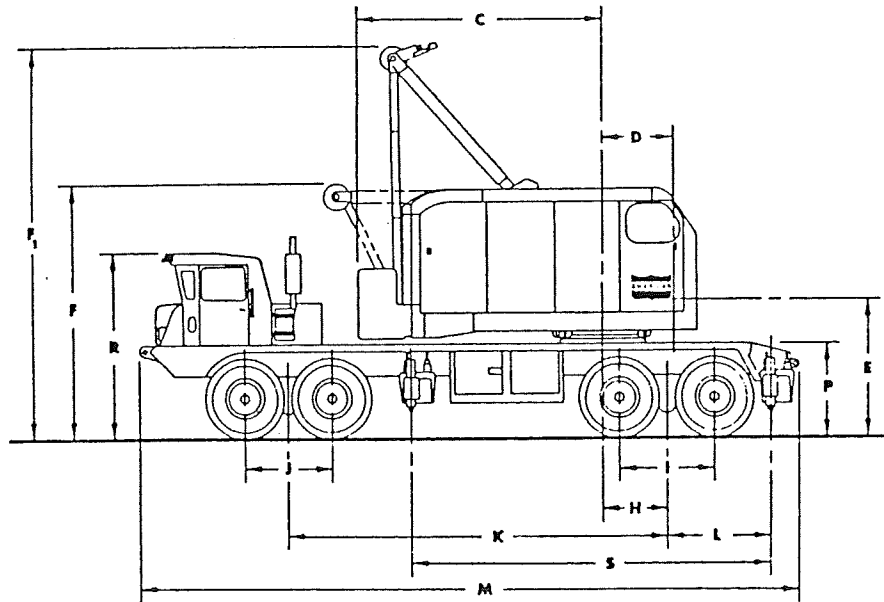

- A. Width of cab 9' 0"
- B. Height to top of cab 11' 11½"
- C. Tail Swing 12' 1"
- D. Centerline of rotation to centerline of boom foot 3' 8"
- E. Ground to centerline boom foot 6' 5½"
- F. Height over A-Frame (lowered) 12' 4½"
- F₁. Height over A-Frame (raised) 19' 1½"
- G. Ground to bottom of counterweight ... 4' 7"
- H. Centerline of rotation to centerline of rear bogie 3' 6"
- I. Distance between rear axles 4' 10"
- J. Distance between front axles 4' 6"
- K. Centerline of rear bogie to centerline of front bogie 18' 9"
- L. Centerline of rear bogie to centerline of rear outrigger 5' 6½"
- M. Overall length 32' 9½"
- N. Overall width 11' 0"
- O. Outriggers extended w/screw jacks 10' 0"
- O₁. Outriggers extended w/hydraulic outriggers 9' 6"
- P. Height over mounting plate 4' 4½"
- R. Height over carrier cab 8' 11"
- S. Centerline of rear outrigger to centerline of front outrigger 18' 0½"
- Turning radius 56'
- Clearance (under rear equalizing beam) ... 11"
- Clearance (under rear differential) 14"

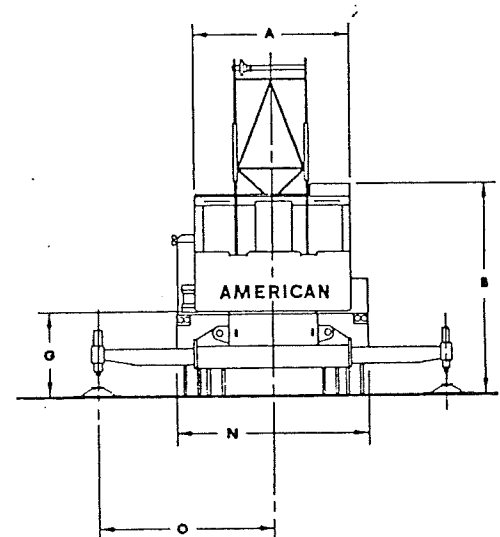

AMERICAN

Lifting Capacities

BOOM LENGTH (FEET)	RADIUS IN FEET	BOOM ANGLE DEGREES	FREE		OUTRIGGERS SET		FEET FROM BOOM POINT TO GROUND
			OVER SIDE	OVER REAR	OVER SIDE	OVER REAR	
40'	11	80.5		101,500	150,000*	150,000*	45.91
	12	79.0		89,330	150,000*	150,000*	45.73
	15	74.6		65,500	135,660*	135,660*	45.02
	20	67.0		45,020	101,000*	101,000*	43.27
	25	58.8	27,770	34,060	71,000	76,700	40.68
	30	49.9	22,070	27,230	53,160	57,890	37.05
	35	39.5	18,180	22,550	42,300	46,310	31.89
	40	25.8	15,350	19,150	34,980	36,080*	23.84
50'	13	80.1		79,610	150,000*	150,000*	55.71
	15	77.7		65,380	135,660*	135,660*	55.32
	20	71.8	36,850	44,900	100,820*	100,820*	53.95
	25	65.6	27,650	33,940	71,010	76,700	51.99
	30	59.1	21,950	27,110	53,130	57,860	49.35
	35	52.0	18,060	22,430	42,260	46,260	45.88
	40	44.2	15,250	19,040	34,940	38,410	41.34
	50	22.9	11,420	14,410	25,710	27,940*	25.92
60'	14	80.8		71,700	145,350*	145,350*	65.68
	15	79.8		65,260	135,660*	135,660*	65.51
	20	74.9	36,720	44,770	100,640*	100,640*	64.39
	25	69.9	27,520	33,800	70,990	76,660	62.80
	30	64.7	21,810	26,970	53,080	57,800	60.69
	35	59.2	17,930	22,300	42,190	46,190	58.01
	40	53.4	15,110	18,900	34,870	38,330	54.65
	50	40.1	11,290	14,290	25,630	28,350	45.14
	60	20.8	8,810	11,290	20,030	22,260	27.78
70'	16	80.5		59,680	127,180*	127,180*	75.49
	20	77.1	36,540	44,590	100,390*	100,390*	74.69
	25	72.9	27,330	33,620	70,920	76,590	73.35
	30	68.5	21,630	26,780	52,990	57,690	71.59
	35	64.0	17,740	22,110	42,080	46,070	69.38
	40	59.3	14,930	18,710	34,740	38,200	66.67
	50	49.2	11,110	14,100	25,490	28,210	59.41
	60	37.0	8,640	11,120	19,890	22,130	48.59
	70	19.2	6,900	9,010	16,120	18,020	29.48
80'	17	80.9	42,690	54,910	119,700*	119,700*	85.46
	20	78.7	36,380	44,420	100,160*	100,160*	84.92
	25	75.1	27,160	33,440	70,860	76,510	83.75
	30	71.3	21,450	26,600	52,890	57,590	82.24
	35	67.5	17,560	21,930	41,960	45,950	80.35
	40	63.5	14,750	18,530	34,610	38,070	78.06
	50	55.1	10,930	13,920	25,350	28,060	72.10
	60	45.8	8,460	10,940	19,750	21,980	63.77
	70	34.5	6,730	8,840	15,990	17,880	51.78
80	17.9	5,440	7,280	13,270	14,920	31.07	
90'	19	80.7	38,340	47,300	106,100*	106,100*	95.26
	20	80.0	36,220	44,260	99,940*	99,940*	95.09
	25	76.8	26,990	33,270	70,790	76,430	94.06
	30	73.5	21,280	26,420	52,790	57,480	92.73
	35	70.1	17,390	21,750	41,840	45,820	91.08
	40	66.7	14,570	18,350	34,480	37,930	89.09
	50	59.5	10,750	13,740	25,210	27,920	83.99
	60	51.7	8,290	10,760	19,600	21,830	77.10
70	43.0	6,560	8,670	15,840	17,730	67.82	

BOOM LENGTH (FEET)	RADIUS IN FEET	BOOM ANGLE DEGREES	FREE		OUTRIGGERS SET		FEET FROM BOOM POINT TO GROUND
			OVER SIDE	OVER REAR	OVER SIDE	OVER REAR	
90'	80	32.5	5,280	7,110	13,130	14,780	54.75
	90	16.9	4,280	5,900	11,090	12,540	32.55
100'	21	80.4	33,760	41,370	89,130*	89,130*	105.07
	25	78.1	26,800	33,070	70,710	76,340	104.31
	30	75.2	21,080	26,220	52,670	57,360	103.12
	35	72.2	17,190	21,540	41,710	45,680	101.65
	40	69.1	14,370	18,150	34,340	37,780	99.89
	50	62.8	10,550	13,540	25,050	27,750	95.42
	60	56.1	8,080	10,550	19,430	21,650	89.49
	70	48.9	6,350	8,460	15,660	17,550	81.77
	80	40.7	5,070	6,910	12,960	14,600	71.61
	90	30.7	4,080	5,710	10,920	12,370	57.54
	100	16.0	3,290	4,750	9,310	10,610	33.95
110'	22	80.8	31,550	38,770	72,820*	72,820*	115.04
	25	79.2	26,610	32,880	70,630	73,240*	114.51
	30	76.5	20,890	26,030	52,560	57,230	113.43
	35	73.8	16,990	21,350	41,580	45,540	112.11
	40	71.1	14,170	17,950	34,190	37,630	110.52
	50	65.5	10,350	13,340	24,880	27,590	106.53
	60	59.6	7,880	10,350	19,260	21,480	101.31
	70	53.3	6,160	8,260	15,490	17,370	94.65
	80	46.4	4,880	6,710	12,780	14,420	86.17
	90	38.7	3,890	5,510	10,740	12,190	75.19
	100	29.2	3,100	4,560	9,150	10,440	60.19
	110	15.2		3,770	7,860	9,030	35.29
120'	24	80.6	27,920	34,480	61,190*	61,190*	124.84
	25	80.1	26,440	32,700	61,380*	61,380*	124.67
	30	77.7	20,700	25,840	52,450	57,110	123.69
	35	75.2	16,800	21,160	41,440	45,410	122.48
	40	72.7	13,980	17,760	34,050	37,480	121.05
	50	67.6	10,160	13,140	24,730	27,420	117.43
	60	62.4	7,690	10,160	19,090	21,310	112.76
	70	56.8	5,960	8,060	15,310	17,200	106.86
	80	50.8	4,680	6,520	12,610	14,240	99.51
	90	44.3	3,700	5,320	10,570	12,010	90.33
	100	37.0		4,370	8,970	10,270	78.59
	110	28.0		3,590	7,690	8,860	62.71
	120	14.5			6,630	7,700	36.56
130'	25	80.9			51,180*	51,180*	134.81
	30	78.6			51,030*	51,030*	133.91
	35	76.4			41,300	45,260	132.80
	40	74.1			33,890	37,320	131.48
	50	69.4			24,550	27,250	128.18
	60	64.6			18,910	21,130	123.94
	70	59.6			15,130	17,010	118.63
	80	54.4			12,420	14,050	112.12
	90	48.7			10,370	11,820	104.14
	100	42.5			8,780	10,070	94.29
	110	35.4			7,500	8,670	81.84
120	26.8			6,440	7,510	65.12	
130	13.9			5,550	6,450	37.78	
140'	27	80.7			43,780*	43,780*	144.62
	30	79.5			43,780*	43,780*	144.10

BOOM LENGTH (FEET)	RADIUS IN FEET	BOOM ANGLE DEGREES	FREE		OUTRIGGERS SET		FEET FROM BOOM POINT TO GROUND
			OVER SIDE	OVER REAR	OVER SIDE	OVER REAR	
140'	35	77.4			41,170	43,340*	143.07
	40	75.3			33,740	37,160	141.85
	50	71.0			24,390	27,080	138.81
	60	66.6			18,730	20,950	134.92
	70	62.0			14,950	16,830	130.09
	80	57.3			12,230	13,860	124.22
	90	52.2			10,180	11,630	117.12
	100	46.8			8,590	9,880	108.55
	110	40.9			7,310	8,480	98.08
	120	34.1			6,250	7,320	84.95
	130	25.8			5,370	6,350	67.43
140	13.4			4,610	5,320	38.95	
150'	28	80.9			36,760*	36,760*	154.59
	30	80.2			36,670*	36,670*	154.26
	35	78.2			36,250*	36,250*	153.30
	40	76.3			33,590	35,730*	152.17
	50	72.3			24,220	26,910	149.35
	60	68.2			18,560	20,770	145.75
	70	64.0			14,760	16,640	141.32
	80	59.7			12,040	13,680	135.96
	90	55.1			10,000	11,440	129.54
	100	50.3			8,400	9,690	121.91
	110	45.1			7,120	8,290	112.77
	120	39.4			6,060	7,130	101.71
	130	32.9			5,180	6,170	87.94
	140	24.9			4,430	5,340	69.66
150	13.0			3,780	4,320*	40.08	
160'	30	80.8			31,960*	31,960	164.40
	35	79.0			31,560*	31,560	163.50
	40	77.1			30,760*	30,760	162.44
	50	73.4			24,050	26,730	159.81
	60	69.6			18,370	20,580	156.47
	70	65.8			14,570	16,450	152.36
	80	61.8			11,850	13,480	147.42
	90	57.6			9,800	11,240	141.56
	100	53.2			8,200	9,490	134.65
	110	48.6			6,920	8,080	126.50
	120	43.6			5,860	6,930	116.84
	130	38.1			4,980	5,960	105.21
	140	31.8			4,230	5,140	90.82
150	24.1			3,590	4,430	71.81	
160	12.5			3,020	3,390*	41.17	
170'	31	81.0			27,980*	27,980*	174.36
	35	79.6			27,330*	27,330*	173.68
	40	77.9			26,350*	26,350*	172.69
	50	74.4			23,880	24,510*	170.22
	60	70.9			18,190	20,400	167.10
	70	67.3			14,390	16,260	163.27
	80	63.6			11,660	13,290	158.69
	90	59.7			9,600	11,040	153.28
	100	55.7			8,000	9,290	146.94
	110	51.5			6,720	7,880	139.55

BOOM LENGTH (FEET)	RADIUS IN FEET	BOOM ANGLE DEGREES	FREE		OUTRIGGERS SET		FEET FROM BOOM POINT TO GROUND
			OVER SIDE	OVER REAR	OVER SIDE	OVER REAR	
170'	120	47.1			5,660	6,730	130.92
	130	42.2			4,780	5,760	120.75
	140	36.9			4,030	4,940	108.59
	150	30.8			3,390	4,240	93.60
	160	23.4				3,620	73.89

These ratings comply with ANSI B30.5 Code. They are applicable only when the crane is used in accordance with good operating practice, including the limitations shown on sheet 3499 of the Operator's Manual.

Ratings are in pounds and do not exceed 85% of the load which would cause tipping at the given radii, with crane standing level on a firm uniformity supporting surface.

Tire inflation pressure for "Free Ratings" is 100 P.S.I. Tire pressure should be reduced for over-the-road travel.

Do not make a lift over the front of a truck crane, either with or without outriggers. If such a lift is unavoidable, consult American Hoist for special instructions and reduced ratings. See back of sheet 3499 of Operator's Manual for definition of working areas on various types of cranes.

Asterisk (*) areas on this chart indicate ratings which are limited by strength of material or factors other than stability. "RADIUS IN FEET" is the horizontal distance at ground level from the center pin to a vertical line through the center of gravity of the suspended load.

Blocks, slings, buckets and other load carrying devices are considered part of the load.

When using the main boom fall with jib in place, the main fall ratings must be reduced by the jib effective weight shown on the jib rating chart. The weight of all suspended blocks, slings, etc., at the main fall and twice the weight of any such devices at the jib fall are to be considered as part of the main boom load.

Ratings shown on this chart make no allowance for such factors as the effect of freely suspended loads, wind, ground conditions, inflation of rubber tires and operating speeds. The user, therefore, shall reduce ratings in order to take these conditions into account.

The Boom Hoist Line is 11 parts of 5/8 inch diameter 6 x 26, WS, FW, RAL, IWRC, IPS wire rope with a minimum breaking strength of not less than 35,800 pounds.

Pendant Suspension Line is 2 parts of 1/4 inch Monolay High strength with a minimum breaking strength of 172,800 pounds.

Main Load Line is 7/8 inch diameter 6 x 25, FW, RRL, IWRC, IPS wire rope with a minimum breaking strength of not less than 69,200 pounds.

Erection over the rear or over the side must be done with the A-frame fully raised and the outriggers fully extended and set. Blocks, slings, and other load-carrying devices must be on the ground during erection.

MAXIMUM BOOM AND JIB SELF-ERECTION DATA			
OVER THE END		OVER THE SIDE	
BOOM LENGTH	JIB LENGTH	BOOM LENGTH	JIB LENGTH
#7HL JIB	170'	60'	170'

No. 7HL Jib	Jib Offset "A"	Jib Length			
		30'	40'	50'	60'
Max. Jib Capacity in Pounds	0 to 6'	*16,000	*14,000	11,000	7,000
	9'	*16,000	12,000	9,300	6,250
	12'	*14,000	10,800	8,000	5,500
	15'		9,500	7,000	4,750
	18'			6,000	4,000
Effective Jib Weight at Boom Point		1,400	1,950	2,630	3,100

Jib capacities based on 80 ft. minimum boom length, for capacities on shorter booms consult factory.

The jib load rating is the lesser of (a) the maximum jib rating, or (b) the main boom rating at the jib working radius, reduced by 200 pounds and by the weight of all suspended load-carrying devices. The maximum jib working radius is limited to the maximum radius for which the ratings are shown for the boom on which the jib is mounted. The main boom rating with the jib in place must be reduced by the effective jib weight, the weight of the main fall blocks and slings, and twice the weight of the jib tackle.

Ratings Marked Thus * Require 7/8" Dia. Load Rope.
Maximum Rating Using 3/4" Dia. Load Rope is 12500 Lbs.

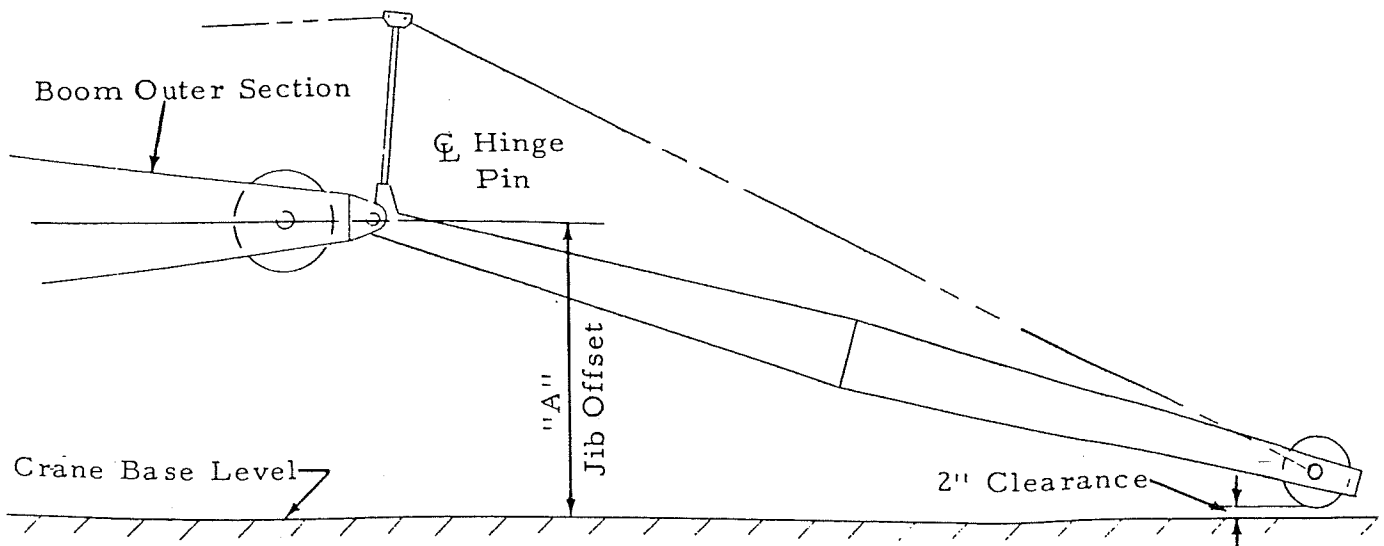

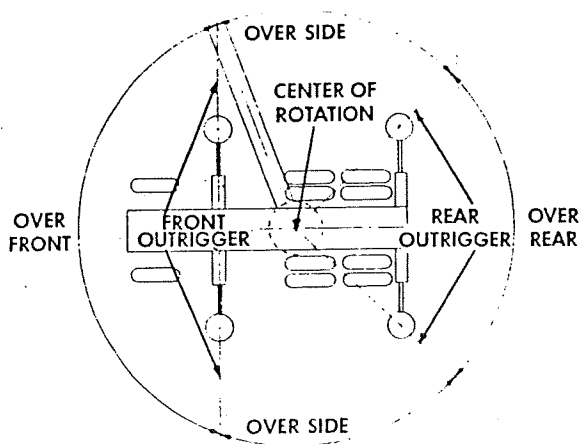

DIAGRAM NO. 2
OUTRIGGERS EXTENDED & SET

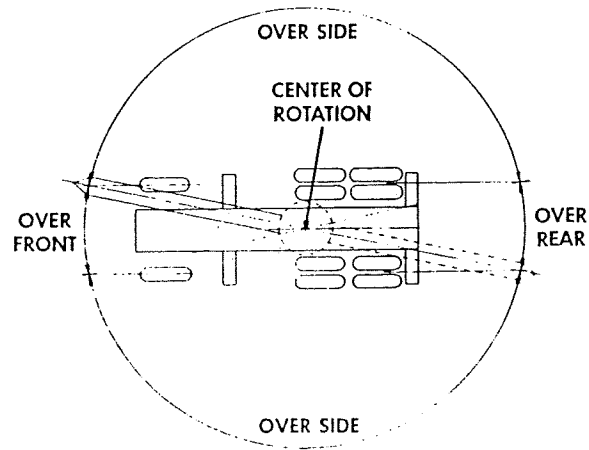

DIAGRAM NO. 1
FREE RATINGS

