

General Dimensions

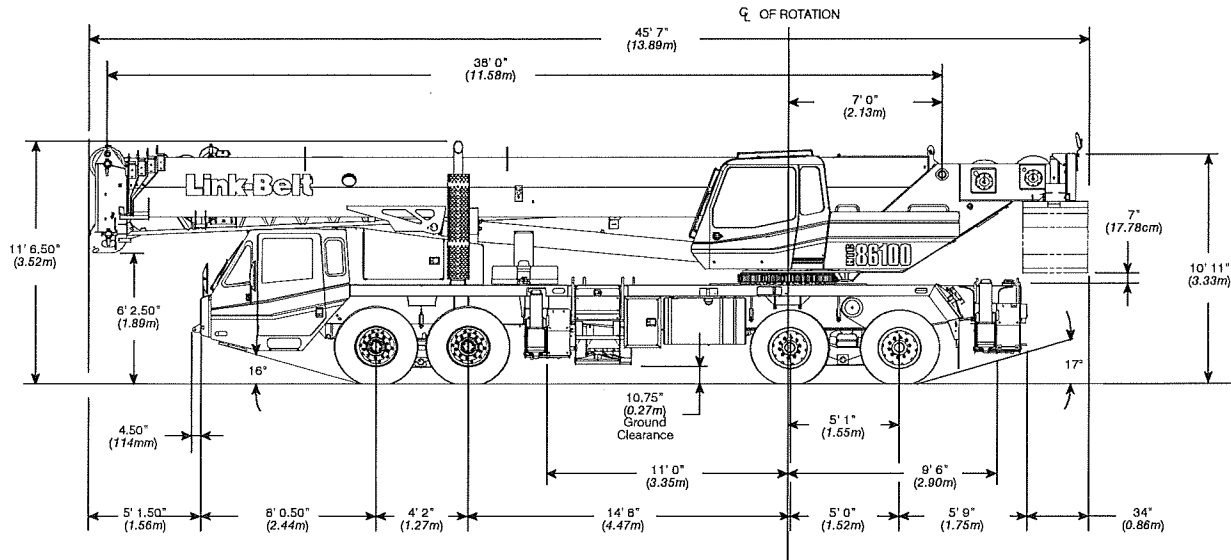

Turning Radius	English	Metric
Wall to wall over carrier	48' 4"	14.7m
Wall to wall over boom	49' 2"	15.0m
Wall to wall over boom attachment	51' 0"	15.5m
Curb to curb	44' 1"	13.4m
Centerline of tire	43' 4"	13.2m

Tail Swing	English	Metric
With counterweight	13' 8"	4.2m
Without counterweight	13' 1"	4.0m

Overall Width	English	Metric
With up to 32,500 lb (14 741.8kg) counterweight	8' 6"	2.6m
With 39,500 lb (17 916.9kg) counterweight	11' 0"	3.4m

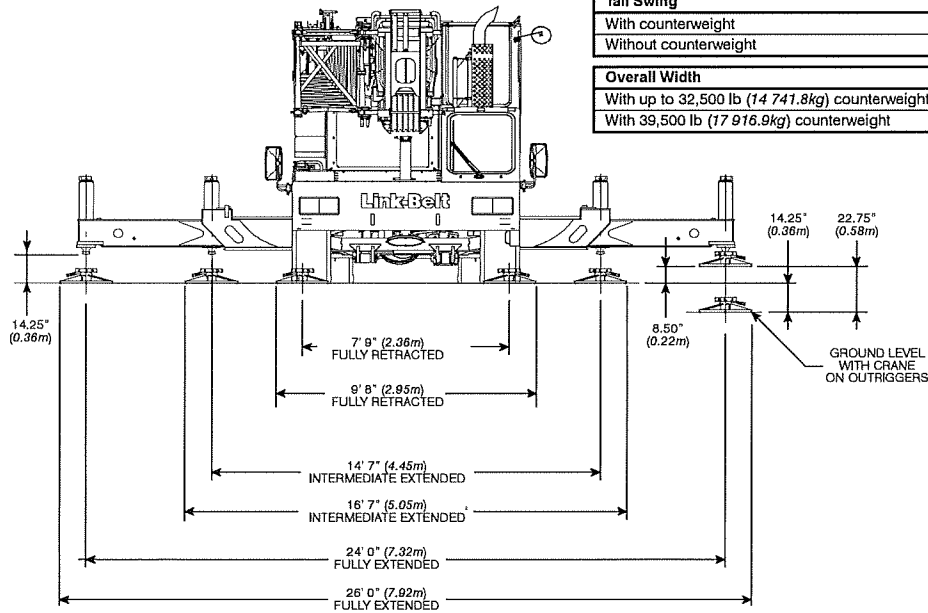

Not To Scale

Working Range Diagram

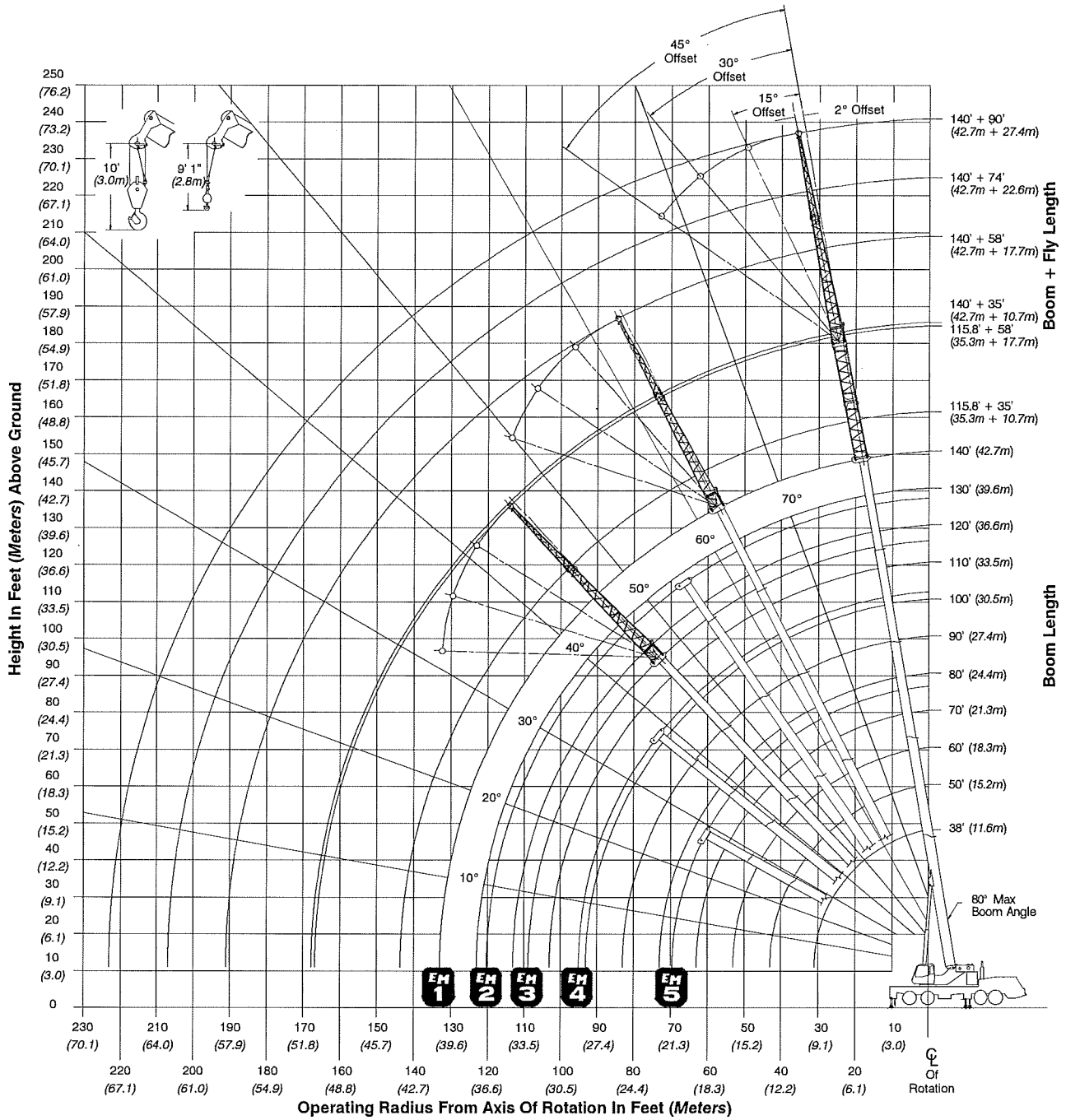

Main Boom Lift Capacity Charts – Optional

32,500 lb Counterweight – Fully Extended Outriggers – 360° Rotation (All Capacities Are Listed In Pounds)												
Radius (ft)	Boom Length (ft)											Radius (ft)
	38	50	60	70	76.5/80	90	100	110	120	130	140	
7	200,000***											7
8	180,000*											8
9	167,100*											9
10	158,300*	152,100*	117,900	89,700								10
12	142,700*	138,700*	108,800	85,000	85,100**							12
15	119,300	121,400	106,500	78,800	78,400**	57,700						15
20	87,600	89,800	90,200	70,300	76,500**	56,200	49,100	42,500				20
25	68,000	70,300	70,800	63,600	70,300**	55,300	45,800	42,500	33,700	29,700		25
30	54,700	57,100	57,600	58,100	58,700	54,500	45,200	38,300	31,200	29,400	24,400	30
35		47,500	49,100	49,400	49,200	48,800	42,500	35,500	30,900	29,100	24,100	35
40		40,500	41,600	41,800	41,600	41,100	38,200	33,400	30,600	28,800	24,000	40
45			34,600	34,900	34,600	34,200	33,700	30,300	29,900	28,600	23,800	45
50			29,300	29,600	29,400	28,900	28,800	27,900	27,800	26,800	23,700	50
55				25,500	25,300	26,000	24,800	24,700	25,300	24,800	23,600	55
60				22,500	22,400	22,800	21,500	22,300	22,000	21,900	22,100	60
65					20,000	20,100	20,000	19,600	19,300	20,000	19,600	65
70					17,700	17,800	17,800	17,700	18,100	17,700	17,400	70
75						15,800	16,500	16,500	16,200	15,800	15,500	75
80						14,200	14,900	14,800	14,500	14,100	13,800	80
85							13,500	13,400	13,100	12,700	12,500	85
90							12,200	12,200	11,900	11,600	11,300	90
95								11,100	10,800	10,500	10,200	95
100								10,100	9,800	9,500	9,200	100
105									8,900	8,600	8,300	105
110									8,100	7,800	7,500	110
115										7,100	6,800	115
120										6,400	6,100	120
125											5,500	125
130											5,000	130

* Special Conditions Or Wire Rope Required
 ** 76.5 EM5 mode
 *** Over Rear

This information is not for crane operation. Operator must refer to the in-cab information for crane operation. Rated lifting capacities shown on fully extended outriggers do not exceed 85% of the tipping loads and on tires do not exceed 75% of the tipping loads.

32,500 lb Counterweight – Fully Extended Outriggers – 360° Rotation (All Capacities Are Listed In Pounds)									
140 ft Main Boom Length 2° Fly Offset					140 ft Main Boom Length 15° Fly Offset				
Radius (ft)	Fly Length (ft)				Radius (ft)	Fly Length (ft)			
	35	58	74	90		35	58	74	90
35	12,100				35				
40	12,100				40				
45	12,100	8,500			45	11,500			
50	12,100	8,400	6,600		50	11,400			
55	12,100	8,300	6,600	5,200	55	11,200			
60	12,100	8,100	6,600	5,200	60	11,000	7,200		
65	11,900	8,000	6,600	5,200	65	10,800	7,000	6,300	
70	11,700	7,800	6,600	5,200	70	10,600	6,800	6,000	4,800
75	11,500	7,700	6,600	5,100	75	10,400	6,700	5,700	4,500
80	11,300	7,500	6,400	4,800	80	10,200	6,500	5,400	4,200
85	11,000	7,300	6,000	4,500	85	10,000	6,300	5,100	4,000
90	10,500	7,100	5,700	4,200	90	9,700	6,200	4,900	3,700
95	10,100	6,900	5,400	4,000	95	9,400	6,000	4,600	3,500
100	9,700	6,700	5,100	3,700	100	9,000	5,900	4,400	3,300
105	8,800	6,500	4,900	3,500	105	8,700	5,700	4,200	3,100
110	8,000	6,300	4,700	3,300	110	8,400	5,600	4,100	3,000
115	7,300	6,000	4,500	3,200	115	7,600	5,500	3,900	2,800
120	6,600	5,800	4,300	3,000	120	6,900	5,300	3,700	2,700
125	6,000	5,600	4,100	2,800	125	6,300	5,100	3,600	2,500
130	5,500	5,300	3,900	2,700	130	5,700	4,900	3,500	2,400
135	5,000	5,200	3,800	2,500	135	5,200	4,700	3,300	2,300
140	4,500	4,900	3,600	2,400	140	4,700	4,600	3,200	2,200
145	4,100	4,400	3,500	2,300	145	4,200	4,400	3,100	2,100
150	3,700	4,000	3,400	2,200	150	3,800	4,300	3,000	2,000
155	3,300	3,700	3,200	2,100	155	3,400	4,000	2,900	1,900
160	2,900	3,300	3,100	2,000	160	3,000	3,600	2,900	1,800
165	2,500	2,900	2,700	1,900	165	2,600	3,200	2,800	1,700
170		2,600	2,400	1,800	170		2,800	2,700	1,600
175		2,300	2,100	1,800	175		2,500	2,300	1,600
180		2,000	1,800	1,700	180		2,100	2,000	1,500
185		1,700	1,500	1,400	185		1,800	1,700	1,500
190			1,200	1,200	190			1,400	1,400
195			1,000	900	195			1,100	1,100
200			800		200			800	900

This information is not for crane operation. Operator must refer to the in-cab information for crane operation. Rated lifting capacities shown on fully extended outriggers do not exceed 85% of the tipping loads and on tires do not exceed 75% of the tipping loads.

32,500 lb Counterweight – Fully Extended Outriggers – 360° Rotation (All Capacities Are Listed In Pounds)									
140 ft Main Boom Length 30° Fly Offset					140 ft Main Boom Length 45° Fly Offset				
Radius (ft)	Fly Length (ft)				Radius (ft)	Fly Length (ft)			
	35	58	74	90		35	58	74	90
35					35				
40					40				
45					45				
50					50				
55	10,000				55				
60	9,800				60				
65	9,700				65	8,800			
70	9,500				70	8,800			
75	9,400	5,700	4,600		75	8,700			
80	9,200	5,600	4,400	3,600	80	8,600			
85	9,100	5,500	4,200	3,400	85	8,600	4,900	3,700	
90	9,000	5,400	4,100	3,200	90	8,500	4,900	3,500	2,900
95	8,800	5,300	3,900	3,000	95	8,400	4,800	3,400	2,700
100	8,500	5,200	3,700	2,900	100	8,200	4,800	3,300	2,600
105	8,200	5,100	3,600	2,700	105	8,000	4,700	3,200	2,400
110	8,000	5,000	3,500	2,600	110	7,800	4,700	3,100	2,300
115	7,700	4,900	3,300	2,400	115	7,600	4,700	3,000	2,200
120	7,200	4,800	3,200	2,300	120	7,400	4,600	2,900	2,100
125	6,500	4,700	3,100	2,200	125	6,700	4,500	2,800	2,000
130	5,900	4,500	3,000	2,100	130	6,000	4,400	2,700	1,900
135	5,400	4,400	2,900	2,000	135	5,400	4,300	2,700	1,800
140	4,800	4,300	2,800	1,900	140		4,200	2,600	1,800
145	4,400	4,200	2,800	1,800	145		4,100	2,600	1,700
150	3,900	4,100	2,700	1,700	150		4,000	2,500	1,600
155	3,500	4,000	2,600	1,700	155		4,000	2,500	1,600
160		3,800	2,600	1,600	160		3,900	2,500	1,500
165		3,400	2,500	1,500	165			2,500	1,500
170		3,000	2,500	1,500	170			2,500	1,400
175		2,600	2,500	1,400	175			2,500	1,400
180		2,200	2,200	1,400	180				1,400
185			1,800	1,400	185				1,400
190			1,500	1,300	190				1,400
195			1,200	1,300					
200				1,000					

This information is not for crane operation. Operator must refer to the in-cab information for crane operation. Rated lifting capacities shown on fully extended outriggers do not exceed 85% of the tipping loads and on tires do not exceed 75% of the tipping loads.

32,500 lb Counterweight – On Tires – Stationary – Boom Centered Over Rear (All Capacities Are Listed In Pounds)								
Radius (ft)	Boom Length (ft)							Radius (ft)
	38	50	60	70	80	90	100	
10	28,300							10
12	25,400	26,900						12
15	21,800	23,400	24,300					15
20	16,700	18,000	19,300	20,100				20
25	13,000	14,900	15,700	16,100	16,300			25
30	10,100	12,100	13,100	13,500	13,800	13,900	13,800	30
35		9,900	10,900	11,400	11,800	11,900	11,800	35
40		8,000	9,100	9,600	10,000	10,100	10,100	40
45			7,600	8,100	8,500	8,700	8,600	45
50			6,300	6,900	7,200	7,400	7,300	50
55				5,700	6,100	6,300	6,200	55
60				4,800	5,200	5,300	5,300	60
65					4,300	4,500	4,500	65
70					3,600	3,800	3,700	70
75						3,100	3,100	75
80						2,500	2,500	80
85							1,900	85
90							1,500	90

32,500 lb Counterweight – On Tires – Pick & Carry (1 mph) – Boom Centered Over Rear (All Capacities Are Listed In Pounds)								
Radius (ft)	Boom Length (ft)							Radius (ft)
	38	50	60	70	80	90	100	
10	18,200							10
12	16,000	17,500						12
15	13,200	14,800	15,600					15
20	9,500	11,300	12,200	12,700				20
25	6,700	8,600	9,600	10,000	10,400			25
30	4,400	6,500	7,500	8,000	8,300	8,500	8,500	30
35		4,700	5,800	6,300	6,700	6,900	6,800	35
40		3,300	4,400	5,000	5,300	5,500	5,500	40
45			3,300	3,900	4,200	4,400	4,400	45
50			2,300	2,800	3,200	3,400	3,300	50
55				2,000	2,400	2,600	2,500	55
60				1,300	1,700	1,900	1,800	60
65					1,100	1,200	1,200	65

This information is not for crane operation. Operator must refer to the in-cab information for crane operation. Rated lifting capacities shown on fully extended outriggers do not exceed 85% of the tipping loads and on tires do not exceed 75% of the tipping loads.

39,500 lb Counterweight – Fully Extended Outriggers – 360° Rotation (All Capacities Are Listed In Pounds)												
Radius (ft)	Boom Length (ft)											Radius (ft)
	38	50	60	70	76.5/80	90	100	110	120	130	140	
7	200,000***											7
8	180,000*											8
9	167,600*											9
10	158,800*	152,100*	117,900	89,700								10
12	143,600*	138,700*	108,800	85,000	85,100**							12
15	123,700	122,600	106,500	78,800	78,400**	57,700						15
20	91,300	93,500	93,800	70,300	76,500**	56,200	49,100	42,500				20
25	71,000	73,300	73,800	63,600	73,300**	55,300	45,800	42,500	33,700	29,700		25
30	57,200	59,600	60,100	58,100	61,100	54,500	45,200	38,300	31,200	29,400	24,400	30
35		49,700	50,300	51,400	51,200	50,900	42,500	35,500	30,900	29,100	24,100	35
40		42,200	43,700	44,000	43,800	43,400	38,200	33,400	30,600	28,800	24,000	40
45			37,900	38,200	38,100	37,700	34,600	30,300	29,900	28,600	23,800	45
50			32,400	32,700	32,500	32,000	31,500	27,900	27,800	26,800	23,700	50
55				28,200	28,000	27,600	27,300	25,600	25,800	24,800	23,600	55
60				24,600	24,500	24,100	24,100	23,600	24,200	23,000	22,100	60
65					21,500	22,300	21,100	21,400	21,600	21,300	20,600	65
70					19,700	19,900	18,700	19,500	19,100	19,200	19,200	70
75						17,700	17,500	17,400	17,000	17,700	17,400	75
80							16,000	16,000	15,600	15,900	15,600	80
85								14,600	14,600	14,800	14,400	85
90								13,800	13,700	13,400	13,000	90
95									12,500	12,300	11,900	95
100									11,500	11,200	10,900	100
105										10,200	9,900	105
110										9,400	9,000	110
115											8,300	115
120											7,500	120
125												125
130												130

* Special Conditions Or Wire Rope Required
 ** 76.5 EM5 mode
 *** Over Rear

This information is not for crane operation. Operator must refer to the in-cab information for crane operation. Rated lifting capacities shown on fully extended outriggers do not exceed 85% of the tipping loads and on tires do not exceed 75% of the tipping loads.

39,500 lb Counterweight – Fully Extended Outriggers – 360° Rotation (All Capacities Are Listed In Pounds)									
140 ft Main Boom Length 2° Fly Offset					140 ft Main Boom Length 15° Fly Offset				
Radius (ft)	Fly Length (ft)				Radius (ft)	Fly Length (ft)			
	35	58	74	90		35	58	74	90
35	12,100				35				
40	12,100				40				
45	12,100	8,500			45	11,500			
50	12,100	8,400	6,600		50	11,400			
55	12,100	8,300	6,600	5,200	55	11,200			
60	12,100	8,100	6,600	5,200	60	11,000	7,200		
65	11,900	8,000	6,600	5,200	65	10,800	7,000	6,300	
70	11,700	7,800	6,600	5,200	70	10,600	6,800	6,000	4,800
75	11,500	7,700	6,600	5,100	75	10,400	6,700	5,700	4,500
80	11,300	7,500	6,400	4,800	80	10,200	6,500	5,400	4,200
85	11,000	7,300	6,000	4,500	85	10,000	6,300	5,100	4,000
90	10,500	7,100	5,700	4,200	90	9,700	6,200	4,900	3,700
95	10,100	6,900	5,400	4,000	95	9,400	6,000	4,600	3,500
100	9,700	6,700	5,100	3,700	100	9,000	5,900	4,400	3,300
105	9,300	6,500	4,900	3,500	105	8,700	5,700	4,200	3,100
110	8,900	6,300	4,700	3,300	110	8,400	5,600	4,100	3,000
115	8,500	6,000	4,500	3,200	115	8,100	5,500	3,900	2,800
120	7,800	5,800	4,300	3,000	120	7,900	5,300	3,700	2,700
125	7,100	5,600	4,100	2,800	125	7,400	5,100	3,600	2,500
130	6,500	5,300	3,900	2,700	130	6,800	4,900	3,500	2,400
135	6,000	5,200	3,800	2,500	135	6,200	4,700	3,300	2,300
140	5,500	5,000	3,600	2,400	140	5,700	4,600	3,200	2,200
145	5,000	4,800	3,500	2,300	145	5,200	4,400	3,100	2,100
150	4,500	4,700	3,400	2,200	150	4,700	4,300	3,000	2,000
155	4,100	4,500	3,200	2,100	155	4,300	4,200	2,900	1,900
160	3,700	4,100	3,100	2,000	160	3,800	4,100	2,900	1,800
165	3,400	3,700	3,100	1,900	165	3,400	4,000	2,800	1,700
170		3,400	3,000	1,800	170		3,600	2,700	1,600
175		3,000	2,800	1,800	175		3,200	2,700	1,600
180		2,700	2,500	1,700	180		2,900	2,600	1,500
185		2,400	2,200	1,600	185		2,500	2,400	1,500
190			1,900	1,600	190			2,100	1,400
195			1,700	1,500	195			1,800	1,400
200			1,400	1,300	200			1,500	1,400
205				1,100	205				1,300
210				900	210				1,000
					215				800

This information is not for crane operation. Operator must refer to the in-cab information for crane operation. Rated lifting capacities shown on fully extended outriggers do not exceed 85% of the tipping loads and on tires do not exceed 75% of the tipping loads.

39,500 lb Counterweight – Fully Extended Outriggers – 360° Rotation (All Capacities Are Listed In Pounds)									
140 ft Main Boom Length 30° Fly Offset					140 ft Main Boom Length 45° Fly Offset				
Radius (ft)	Fly Length (ft)				Radius (ft)	Fly Length (ft)			
	35	58	74	90		35	58	74	90
35					35				
40					40				
45					45				
50					50				
55	10,000				55				
60	9,800				60				
65	9,700				65	8,800			
70	9,500				70	8,800			
75	9,400	5,700	4,600		75	8,700			
80	9,200	5,600	4,400	3,600	80	8,600			
85	9,100	5,500	4,200	3,400	85	8,600	4,900	3,700	
90	9,000	5,400	4,100	3,200	90	8,500	4,900	3,500	2,900
95	8,800	5,300	3,900	3,000	95	8,400	4,800	3,400	2,700
100	8,500	5,200	3,700	2,900	100	8,200	4,800	3,300	2,600
105	8,200	5,100	3,600	2,700	105	8,000	4,700	3,200	2,400
110	8,000	5,000	3,500	2,600	110	7,800	4,700	3,100	2,300
115	7,700	4,900	3,300	2,400	115	7,600	4,700	3,000	2,200
120	7,500	4,800	3,200	2,300	120	7,400	4,600	2,900	2,100
125	7,300	4,700	3,100	2,200	125	7,200	4,500	2,800	2,000
130	7,000	4,500	3,000	2,100	130	7,100	4,400	2,700	1,900
135	6,400	4,400	2,900	2,000	135	6,400	4,300	2,700	1,800
140	5,800	4,300	2,800	1,900	140		4,200	2,600	1,800
145	5,300	4,200	2,800	1,800	145		4,100	2,600	1,700
150	4,800	4,100	2,700	1,700	150		4,000	2,500	1,600
155	4,300	4,000	2,600	1,700	155		4,000	2,500	1,600
160		3,900	2,600	1,600	160		4,000	2,500	1,500
165		3,900	2,500	1,500	165		4,000	2,500	1,500
170		3,700	2,500	1,500	170			2,500	1,400
175		3,300	2,500	1,400	175			2,500	1,400
180		2,900	2,500	1,400	180				1,400
185			2,500	1,400	185				1,400
190			2,200	1,300	190				1,400
195			1,900	1,300					
200				1,300					
205				1,300					
210				1,100					

This information is not for crane operation. Operator must refer to the in-cab information for crane operation. Rated lifting capacities shown on fully extended outriggers do not exceed 85% of the tipping loads and on tires do not exceed 75% of the tipping loads.