

GROVE MODEL RT58D 20 TON CAPACITY

Rough Terrain Crane

Transportation Book

Table of Contents

RANGE DIAGRAM

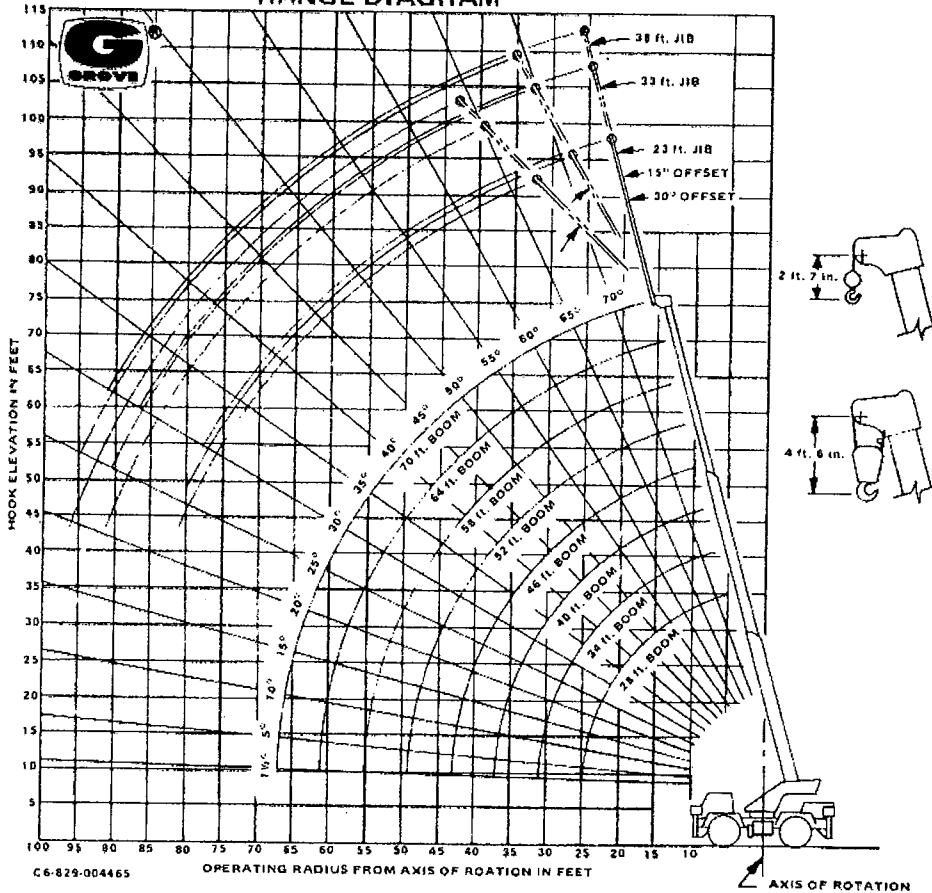

WEIGHT REDUCTIONS FOR LOAD HANDLING DEVICES

23 ft. JIB with 28-70 ft. BOOM	
* Stowed -	381 lbs.
* Erected -	1,950 lbs.

23-38 ft. TELE. JIB with 28-70 ft. BOOM	
* Stowed -	604 lbs.
* Erected (Retracted) -	3,659 lbs.
* Erected (Extended) -	4,583 lbs.

* Reduction of main boom capacities.

HOOK BLOCKS:	
15 ton, 2 sheave	298 lbs.
22 ton, 3 sheave	455 lbs.
12 ton, 1 sheave (15 7/8")	400 lbs.
12 ton, 1 sheave (15 1/8")	285 lbs.
Aux. Boom head	100 lbs.
5 ton headache bail	150 lbs.

NOTE:

All Load Handling Devices and Boom Attachments are Considered Part of the Load and Suitable Allowances MUST BE MADE for Their Combined Weights.

Weights are for Grove furnished equipment.

LIFTING AREA DIAGRAMS

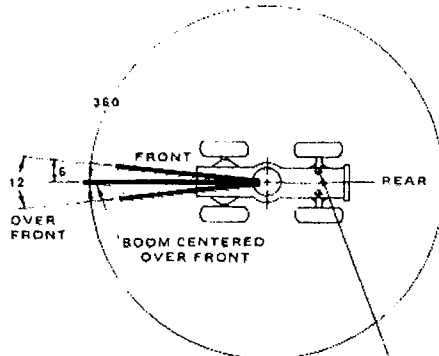

REAR AXLE OSCILLATION LOCKOUTS MUST BE SET TO MAINTAIN 360 CAPACITIES.

NOTE BOLD LINES DETERMINE THE LIMITING POSITION OF ANY LOAD FOR OPERATION WITHIN ANY WORKING AREAS INDICATED.

C6-829-003529

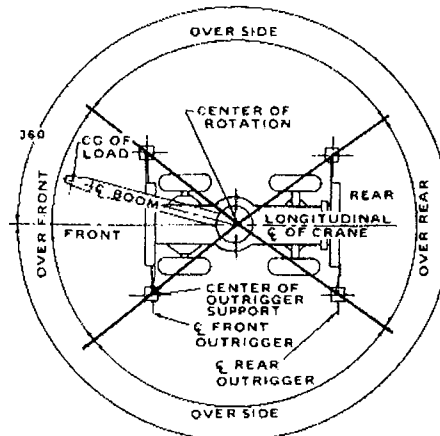

NOTE BOLD LINES DETERMINE THE LIMITING POSITION OF ANY LOAD FOR OPERATION WITHIN WORKING AREAS INDICATED.

NOTE OVER SIDE CAPACITIES CAN BE LIFTED IN THE OVER REAR AREA.

C6-829-001159

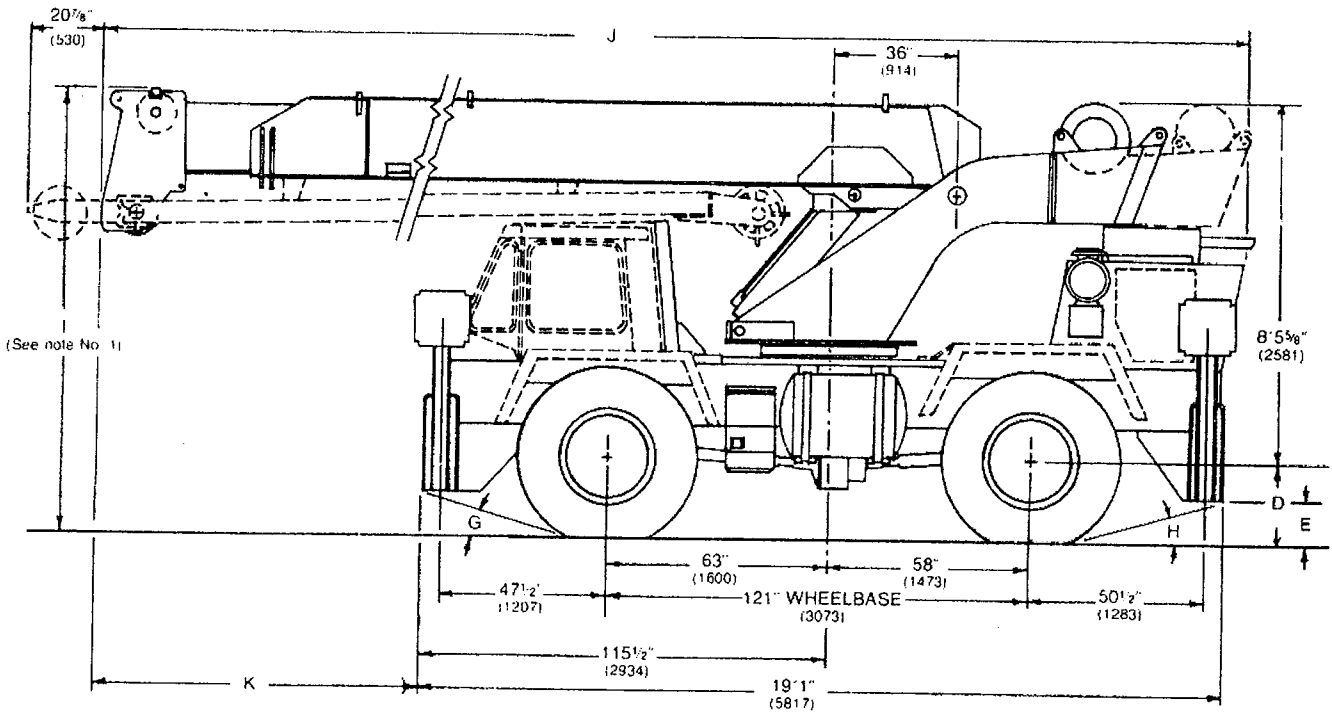

DIMENSIONS

Boom Length Tire Size	A	B	C	D	E	F	G	H		
									24-42 ft. (7.3-12.8 m) or 25-60 ft. (7.6-18.3 m)	28-70 ft. (8.5-21.3 m)
14:00 x 24	62 1/2 in. (1588)	79 1/2 in. (2019)	96 1/2 in. (2451)	24 in. (610)	13 in. (330)	6 1/8 in. (156)	17°	17°	10 ft. 5 7/8 in. (3197)	11 ft. 2 5/8 in. (3150)
17.5 x 25	57 11/16 in. (1473)	77 1/2 in. (1969)	97 5/16 in. (2464)	23 3/16 in. (589)	12 3/16 in. (310)	7 3/16 in. (182)	17°	16°	10 ft. 5 in. (3175)	Not Available
20.5 x 25	57 1/4 in. (1448)	81 1/8 in. (2061)	105 in. (2667)	26 13/16 in. (681)	15 13/26 in. (402)	6 7/16 in. (164)	21°	20°	10 ft. 8 3/4 in. (3270)	11 ft. 5 1/2 in. (3493)

Boom Length	J	K
24-42 ft. (7.3-12.8 m)	31 ft. 9 13/16 in. (9698)	12 ft. 4 3/16 in. (3764)
25-60 ft. (7.6-18.3 m)	32 ft. 5 5/16 in. (9889)	12 ft. 10 11/16 in. (3954)
28-70 ft. (8.5-21.3 m)	35 ft. 9 5/16 in. (10905)	16 ft. 3 11/16 in. (4970)

TURNING RADIUS

27 ft. 1 1/2 in. (8268) (2 wheel steer)

16 ft. 2 1/2 in. (4940) (4 wheel steer)

TAIL SWING

8 ft. 5 1/4 in. (2572) (w/o aux. hoist)

10 ft. 2 7/8 in. (3121) (w/aux. hoist or 70 ft. (21.3 m) boom w/o aux. hoist)

NOTE NO. 1: Add 7 3/8 in. (187) to height for units equipped W/25 ft. - 60 ft. (7.6 m - 18.3 m) or 28 ft. - 70 ft. (8.5 m - 21.3 m) 3 section booms with export cable extension sheaves.

NOTE: Dimensions shown in parentheses are in millimeters (mm).

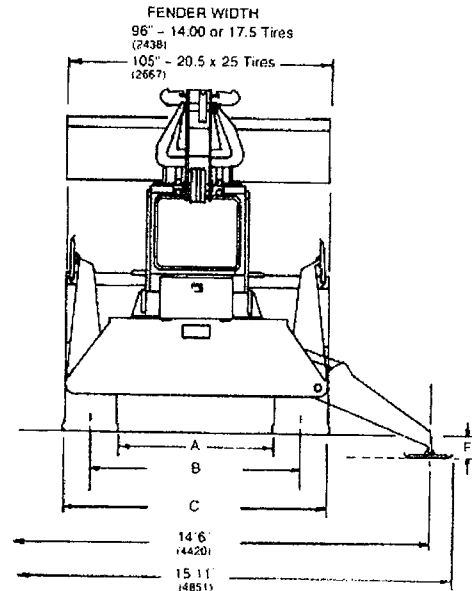

RATED LIFTING CAPACITIES IN POUNDS

ON OUTRIGGERS FULLY EXTENDED - 360°

Radius In Feet	Main Boom Length in Feet							
	28	34	40	46	52	58	64	70
10	40,000 (64)	36,000 (69)	36,000 (73)					
12	35,000 (59.5)	35,000 (65.5)	35,000 (70)	35,000 (73)				
15	28,400 (51.5)	28,400 (59.5)	28,400 (65)	28,400 (69)	28,400 (72)	28,400 (74.5)		
20	21,100 (36.5)	21,100 (49)	21,100 (57)	21,100 (62)	21,100 (66)	21,100 (69.5)	21,100 (72)	20,500 (74)
25		15,450 (36)	15,450 (47.5)	15,450 (54.5)	15,450 (60)	15,450 (64)	15,450 (67)	15,450 (69.5)
30		11,270 (15.5)	11,270 (36.5)	11,270 (46.5)	11,270 (53)	11,270 (58)	11,270 (62)	11,270 (65)
35			8,660 (20)	8,660 (36.5)	8,660 (45.5)	8,660 (51.5)	8,660 (56.5)	8,660 (60)
40				6,940 (23)	6,940 (36.5)	6,940 (45)	6,940 (50.5)	6,940 (55)
45					5,550 (25)	5,550 (37)	5,550 (44.5)	5,550 (49.5)
50						4,500 (26.5)	4,500 (37)	4,500 (43.5)
55							3,600 (28)	3,600 (37)
60							2,850 (13)	2,850 (28.5)
65								2,260 (15.5)
Min. boom angle (deg.) for indicated length (no load)								0
Max. boom length (ft.) at 0 degree boom angle (no load)								70

NOTE: Boom angles are in degrees.

ON OUTRIGGERS FULLY EXTENDED - OVER FRONT

Radius In Feet	Main Boom Length in Feet							
	28	34	40	46	52	58	64	70
10	40,000 (64)	36,000 (69)	36,000 (73)					
12	35,000 (59.5)	35,000 (65.5)	35,000 (70)	35,000 (73)				
15	28,400 (51.5)	28,400 (59.5)	28,400 (65)	28,400 (69)	28,400 (72)	28,400 (74.5)		
20	21,100 (36.5)	21,100 (49)	21,100 (57)	21,100 (62)	21,100 (66)	21,100 (69.5)	21,100 (72)	20,500 (74)
25		17,200 (36)	17,200 (47.5)	17,200 (54.5)	17,200 (60)	17,200 (64)	17,200 (67)	17,200 (69.5)
30		14,050 (15.5)	14,050 (36.5)	14,050 (46.5)	14,050 (53)	14,050 (58)	14,050 (62)	14,050 (65)
35			11,650 (20)	11,650 (36.5)	11,650 (45.5)	11,650 (51.5)	11,650 (56.5)	11,650 (60)
40				9,760 (23)	9,760 (36.5)	9,760 (45)	9,760 (50.5)	9,760 (55)
45					8,160 (25)	8,160 (37)	8,160 (44.5)	8,160 (49.5)
50						6,870 (26.5)	6,870 (37)	6,870 (43.5)
55							5,740 (28)	5,740 (37)
60							4,770 (13)	4,770 (28.5)
65								3,910 (15.5)
Min. boom angle (deg.) for indicated length (no load)								0
Max. boom length (ft.) at 0 degree boom angle (no load)								70

NOTE: Boom angles are in degrees.

ON RUBBER CAPACITIES

14.00 x 24 TIRES

Radius In Feet	Stationary Capacity		Pick & Carry Capacity Up to 2.5 mph Boom Centered (7) Over Front
	Defined Arc (3) Over Front	360° Arc	
10	25,320 (a)	19,170 (a)	24,670 (a)
12	22,950 (a)	15,570 (a)	21,210 (a)
15	18,750 (a)	12,580 (a)	17,320 (a)
20	13,670 (b)	8,140 (b)	12,790 (a)
25	10,320 (b)	5,300 (c)	9,720 (b)
30	7,670 (c)	3,640 (d)	7,670 (c)
35	5,540 (d)	2,520 (e)	5,540 (d)
40	4,200 (e)	1,710 (f)	3,480 (d)
45	3,220 (f)	1,110 (g)	2,710 (e)
50	2,540 (g)		2,150 (f)
55	1,930 (g)		1,630 (g)
60	1,420 (h)		1,170 (g)
65	1,020 (h)		

20.5 x 25 TIRES

Radius In Feet	Stationary Capacity		Pick & Carry Capacity Up to 2.5 mph Boom Centered (7) Over Front
	Defined Arc (3) Over Front	360° Arc	
10	31,300 (a)	27,150 (a)	28,470 (a)
12	27,500 (a)	19,500 (a)	24,550 (a)
15	22,300 (a)	14,300 (a)	20,420 (a)
20	15,800 (b)	8,270 (b)	15,070 (a)
25	10,390 (b)	5,420 (c)	10,390 (b)
30	7,770 (c)	3,800 (d)	5,670 (c)
35	5,870 (d)	2,740 (e)	4,430 (d)
40	4,560 (e)	1,920 (f)	3,510 (d)
45	3,560 (f)	1,200 (g)	2,760 (e)
50	2,760 (g)		2,120 (f)
55	2,110 (g)		1,580 (g)
60	1,640 (h)		1,180 (g)
65	1,300 (h)		

NOTES FOR RUBBER CAPACITIES

- Capacities do not exceed 85% of tipping loads as determined by test in accordance with SAE J-765.
- Capacities are applicable to machines equipped with:

	Cold Inflation	2.5 MPH
14:00 x 24 (20 ply)	115 PSI	110 PSI
20.5 x 25 (20 ply)	80 PSI	65 PSI

Maximum Permissible Boom Length:

(a) 28 ft.	(e) 52 ft.
(b) 34	(f) 58
(c) 40	(g) 64
(d) 46	(h) 70

- Defined Arc - Over front includes +/- 6° on either side of longitudinal centerline of machine.
- Capacities appearing above bold line are based on structural strength and tipping should not be relied upon as a capacity limitation.
- Capacities are applicable only with machine on a firm level surface.
- On rubber lifting with jib not permitted.
- For pick and carry operation, boom must be centered over front of machine and mechanical swing lock engaged. When handling loads in the structural range with capacities close to maximum ratings, travel should be reduced to creep speed and load restrained from swinging.
- Axle lockouts must be functioning before lifting on rubber. (Check automatic lockout system for proper functioning: Refer to "Operation and Maintenance Manual" for description of a proper functioning axle lockout system).
- All lifting depends on proper tire inflation, capacity and condition. Capacities must be reduced for lower tire inflation pressures. See lifting capacity chart for tire used. Damaged tires are hazardous to safe operation of crane.
- Lifting loads at close radii directly over the operator's compartment is not recommended.

	Minimum boom angle for indicated length	Main Boom 70.0 ft.	Main Boom W/23 ft. Jib
Front (No Load)	0°	0°	0°
360° (No Load)	27°	70.0 ft.	93.0 ft.
	55°	58.0 ft.	67.2 ft.

JIB CAPACITIES IN POUNDS

23 ft. "A" FRAME JIB

Main Boom Angle	0° Offset		15° Offset		30° Offset	
	Radius Ref. ft.	Cap. Lbs.	Radius Ref. ft.	Cap. Lbs.	Radius Ref. ft.	Cap. Lbs.
75°	27.0	12,000	32.5	7,700	35.7	5,070
70	33.3	8,160	38.1	7,000	41.2	4,800
65	40.2	5,680	44.9	5,350	47.8	4,500
60	47.0	4,310	51.3	4,220	54.0	3,620
55	53.2	3,330	57.3	3,300	59.8	2,940
50	59.2	2,720	62.9	2,580	65.1	2,390
45	64.7	2,210	68.0	2,130	69.9	2,010
40	69.6	1,750	72.6	1,690	74.2	1,680
35	74.1	1,460	76.6	1,420	77.9	1,420
30	77.8	1,240	80.1	1,210	81.0	1,200

- All capacities are in pounds. 23' (7.1 meter) jib may be used for double line lifting service. Capacities are based on structural strength of 23' (7.1 m) jib at a given main boom angle regardless of main boom length.
- WARNING: Operation of machine with heavier loads than the capacities listed strictly prohibited. Machine tipping with jib occurs rapidly and without advance warning.
- Capacities listed are with fully extended outriggers only.
- WARNING: Lifting on rubber with jib is prohibited.
- Reference radii listed are for fully extended main boom only.
- No load stability on outriggers with 23' (7.1 m) jib installed.
 - Minimum boom angle for fully extended main boom = 0°.
 - Maximum boom length at 0° main boom angle = 93' (28.3 m).

23 ft. – 38 ft. TELE JIB

Boom Angle	23 ft. Jib Length (Fully Retracted)						33 ft. Jib Length						38 ft. Jib Length (Fully Extended)					
	0° Offset		15° Offset		30° Offset		0° Offset		15° Offset		30° Offset		0° Offset		15° Offset		30° Offset	
	Radius Ref. ft.	Cap. Lbs.	Radius Ref. ft.	Cap. Lbs.	Radius Ref. ft.	Cap. Lbs.	Radius Ref. ft.	Cap. Lbs.	Radius Ref. ft.	Cap. Lbs.	Radius Ref. ft.	Cap. Lbs.	Radius Ref. ft.	Cap. Lbs.	Radius Ref. ft.	Cap. Lbs.	Radius Ref. ft.	Cap. Lbs.
75°	27.5	12,500	31.4	7,300	35.0	4,500	29.0	7,600	35.3	4,900	41.5	2,900	31.0	5,000	39.0	3,750	45.4	2,230
70	33.8	8,560	37.8	6,390	40.6	4,150	35.9	6,500	42.5	4,270	48.8	2,650	37.9	4,650	45.6	3,300	51.8	1,990
65	40.2	6,060	44.7	5,750	47.2	3,900	43.9	4,280	50.2	3,820	56.1	2,440	46.3	4,470	53.7	2,950	59.3	1,870
60	47.0	4,480	51.3	4,000	53.6	3,250	51.6	3,840	57.5	3,250	62.8	2,330	54.3	3,100	61.2	2,640	66.4	1,770
55	53.2	3,430	57.3	2,960	59.5	2,710	58.9	2,910	64.3	2,470	69.2	2,230	62.0	2,740	68.4	2,350	72.9	1,680
50	59.2	2,640	62.9	2,230	65.1	2,230	65.7	2,300	70.7	1,860	74.9	1,850	69.2	2,090	75.0	1,800	78.9	1,620
45	64.7	1,980	68.0	1,750	69.9	1,750	71.9	1,810	76.5	1,400	80.2	1,400	75.8	1,640	81.1	1,400	84.3	1,400
40	69.6	1,510	72.6	1,400	74.2	1,400	77.7	1,360	81.7	1,180	84.7	1,180	81.8	1,310	86.4	1,150	89.0	1,080
35	74.0	1,180	76.6	1,100	77.9	1,100	82.8	1,080	86.2	880	88.6	880	87.4	1,000	91.2	880	93.0	880
30	77.8	920	80.1	870	81.0	870	87.3	820	90.2	760	91.8	760	92.0	770	95.2	760	96.3	600

No load stability on outriggers 360° with 23-38 ft. tele-jib installed:

	Tele-jib fully Retracted 93'	33' Tele-jib Length 103'	Tele-jib fully Extended 108'
Minimum boom angle for indicated length boom	0°	0°	0°
Maximum boom length including jib for 0° boom angle	93'	103'	108'

- 23' (7.1 m) tele jib length may be used for double line lifting service. 33' (10.1 m) and 38' (11.6 m) jib lengths may be used for single line lifting service only. Capacities are based on structural strength of 23' - 38' (7.1 - 11.6 m) tele jib at a given main boom angle regardless of main boom length.
- WARNING: Operation of machine with heavier loads than the capacities listed strictly prohibited. Machine tipping with jib occurs rapidly and without advance warning.
- Capacities listed are with fully extended outriggers only.
- WARNING: Lifting on rubber with jib is prohibited.
- Reference radii listed are for fully extended boom only 70' (21.2 m).

LIFTING CAPACITY NOTES

GENERAL:

1. Rated loads as shown on lift chart pertain to this machine as originally manufactured and equipped. Modifications to the machine or use of optional equipment other than that specified can result in a reduction of capacity.
2. Construction equipment can be hazardous if improperly operated or maintained. Operation and maintenance of this machine shall be in compliance with the information in the operator's, parts, and safety manuals supplied with this machine. If these manuals are missing, order replacements from the manufacturer through the distributor.
3. The operator and other personnel associated with this machine shall fully acquaint themselves with the latest applicable American National Standards Institute (ANSI) Safety Standards for cranes.
7. Do not operate at a radius or boom length where capacities are not listed. At these positions, the machine may overturn without any load on the hook.
8. The maximum load which can be telescoped is not definable because of variations in loadings and crane maintenance, but it is safe to attempt retraction and extension within the limits of the capacity chart.
9. When either boom length or radius or both are between values listed, the smallest load shown at either the next larger radius or boom length shall be used.

SETUP:

1. The machine shall be leveled on a firm supporting surface. Depending on the nature of the supporting surface, it may be necessary to have structural supports under the outrigger floats or tires to spread the load to a larger bearing surface.
2. For outrigger operation, outriggers shall be fully extended with tires raised free of crane weight before operating the boom or lifting loads.
3. If machine is equipped with front jack cylinder, the front jack cylinder shall be set in accordance with written procedure.
4. If machine is equipped with extendable counterweight, the counterweight shall be fully extended before operation.
5. Tires shall be inflated to the recommended pressure before lifting on rubber.
6. With certain boom and hoist tackle combinations, maximum capacities may not be obtainable with standard cable lengths.
10. For safe operation, the user shall make due allowances for his particular job conditions, such as: soft or uneven ground, out of level conditions, high winds, side loads, pendulum action, jerking or sudden stopping of loads, hazardous conditions, experience of personnel, two machine lifts, traveling with loads, electric wires, etc. Side pull on boom or jib is extremely dangerous.
11. Power telescoping boom sections must be extended equally at all times.
12. Handling of personnel from the boom is not authorized except with equipment furnished and installed by Grove Manufacturing Company.
13. Keep load handling devices a minimum of 12 inches (30 cm) below boom head when lowering or extending boom.
14. Loaded boom angles give an approximation of the operating radius at specified boom lengths. The boom angle before loading should be greater to account for deflection.
15. Capacities appearing above bold line are based on structural strength and tipping should not be relied upon as a capacity limitation.
16. Capacities for 28 ft. (8.6 m) boom length shall be lifted with the boom fully retracted. If boom is not fully retracted, capacities shall not exceed those shown for the 34 ft. (10.4 m) boom length.
17. Lifting loads at close radii directly over the operator's compartment is not recommended.

DEFINITIONS:

OPERATION:

1. Rated loads at rated radius shall not be exceeded. Do not tip the machine to determine allowable loads. For clamshell or concrete bucket operation, weight of bucket and load must not exceed 80% of rated lifting capacities.
2. Rated loads do not exceed 85% of the tipping load as determined by SAE Crane Stability Test Code J-765a.
3. Rated loads include the weight of hook block, slings and auxiliary lifting devices and their weights shall be subtracted from the listed ratings to obtain the net load to be lifted.
4. Load ratings are based on freely suspended loads. No attempt shall be made to move a load horizontally on the ground in any direction.
5. Rated loads do not account for wind on lifted load or boom. It is recommended when wind velocity is above 20 mph (32 km/h), rated loads and boom lengths shall be appropriately reduced.
6. Rated loads are for lift crane service only.
1. Operating Radius: Horizontal distance from a projection of the axis of rotation to the supporting surface before loading to the center of the vertical hoist line or tackle with load applied.
2. Loaded Boom Angle (Shown in Parenthesis on Main Boom Capacity Chart): is the angle between the boom base section and the horizontal, after lifting the rated load at the rated radius.
3. Working Area: Areas measured in a circular arc about the center line of rotation as shown on the working area diagram.
4. Freely Suspended Load: Load hanging free with no direct external force applied except by the lift cable.
5. Side Load: Horizontal force applied to the lifted load either on the ground or in the air.

