

GROVE®

LOAD CHARTS AP408

COPY

85% STABILITY
ON OUTRIGGERS
75% STABILITY
ON RUBBER

83891
SERIAL NUMBER

NOTES FOR LIFTING CAPACITIES

GENERAL:

1. Rated loads as shown on lift chart pertain to this machine as originally manufactured and equipped. Modifications to the machine or use of optional equipment other than that specified can result in a reduction of capacity.
2. Construction equipment can be hazardous if improperly operated or maintained. Operation and maintenance of this machine shall be in compliance with the information in the Operator's and Safety Handbook, Service Manual, and Parts Manual supplied with this machine. If these manuals are missing, order replacements from the manufacturer through the distributor.
3. The operator and other personnel associated with machine shall fully acquaint themselves with the latest American National Safety Standards (ASME/ANSI) for cranes.

SETUP:

1. The machine shall be level and on a firm supporting surface. Depending on the nature of the supporting surface, it may be necessary to have structural supports under the outrigger floats or tires to spread the load to a larger bearing surface.
2. For outrigger operation, all outriggers shall be properly extended with tires raised free of crane weight before operating the boom or lifting loads.
3. When machine is equipped with front jack cylinder, the front jack cylinder shall be set in accordance with instructions in Operator's & Safety Handbook.
4. When equipped with removable and/or extendible counterweight, the proper counterweight shall be installed and fully extended before and during operation.
5. Tires shall be inflated to the recommended pressure before lifting on rubber.
6. With certain boom and hoist tackle combinations, maximum capacities may not be obtainable with standard cable lengths.
7. Unless approved by the crane manufacturer, do not travel with boom extension or jib erected. Refer to the Operator's and Safety Handbook for job-site travel information.

OPERATION:

1. Rated loads at rated radius shall not be exceeded. Do not attempt to tip the machine to determine allowable loads. For clamshell or concrete bucket operation, weight of bucket and load must not exceed 80% of rated lifting capacities.
2. All rated loads have been tested to and meet the requirements of SAE J1063 - Cantilevered Boom Crane Structures - Method of Test, and do not exceed 85% of the tipping load on outriggers as determined by SAE J765 Crane Stability Test Code.
3. Rated loads include the weight of hookblock, slings and auxiliary lifting devices and their weights shall be subtracted from the listed rating to obtain the net load to be lifted. When more than the minimum required parts of line needed to pick the load are used, the additional rope weight as measured from the lower sheaves of the main boom nose shall be considered part of the load to be lifted. When both the hook block and headache ball are reeved, the lifting device that is NOT in use, including the line as measured from the lower sheave(s) of the nose supporting the unused device, shall be considered part of the load.
4. Load ratings are based on freely suspended loads. No attempt shall be made to move a load horizontally on the ground in any direction.
5. The maximum in-service wind speed is 20 m.p.h. It is recommended when wind velocity is above 20 m.p.h., rated loads and boom lengths shall be appropriately reduced. For machines not in service, the main boom should be retracted and lowered with the swing brake set in wind velocities over 30 m.p.h.
6. Rated loads are for lift crane service only.
7. Do not operate at a radius or boom length where capacities are not listed. At these positions, the machine may overturn without any load on the hook.
8. The maximum load which can be telescoped is not definable because of variations in loadings and crane maintenance, but it is safe to attempt retraction and extension of the boom within the limits of the capacity chart.
9. When the boom length or lift radius or both are between values listed, the smallest load shown at either the next larger radius or next longer or shorter boom length shall be used.
10. For safe operation, the user shall make due allowances for his particular job conditions, such as: soft or uneven ground, out of level conditions, high winds, side loads, pendulum action, jerking or sudden stopping of loads, hazardous conditions, experience of personnel, two machine lifts, traveling with loads, electric wires, etc. Side pull on boom or jib is extremely dangerous.
11. If machine is equipped with individually controlled powered boom sections, the boom sections must be extended equally at all times.
12. Never handle personnel with this machine unless the requirements of the applicable national, state, and local regulations and safety codes are met.
13. Keep load handling devices a minimum of 42 inches below boom head at all times.
14. The boom angle before loading should be greater than the loaded boom angle to account for deflection.
15. Capacities appearing above the bold line are based on structural strength and tipping should not be relied upon as a capacity limitation.
16. Do not lift loads when boom is fully lowered. The Load Moment Indicator (LMI) senses pressure and will not provide warnings or lockout. The crane can become overloaded if lift cylinder(s) is fully retracted.

DEFINITIONS:

1. Operating Radius: Horizontal distance from a projection of the axis of rotation to the supporting surface before loading to the center of the vertical hoist line or tackle with load applied.
2. Loaded Boom Angle (Shown in Parenthesis on Main Boom Capacity Chart): is the angle between the boom base section and the horizontal, after lifting the rated load at the rated radius with the rated boom length.
3. Working Area: Areas measured in a circular arc about the center line of rotation as shown on the working area diagram.
4. Freely Suspended Load: Load hanging free with no direct external force applied except by the lift cable.
5. Side Load: Horizontal force applied to the lifted load either on the ground or in the air.

RATED LIFTING CAPACITIES IN POUNDS
ON OUTRIGGERS FULLY EXTENDED - 360°

13 - 30 FT. BOOM

Radius in Feet	#01	
	13 - 30 FT. BOOM	
	Over Front	360°
5	16,000	16,000
6	15,000	15,000
8	13,000	13,000
10	11,000	11,000
12	9,500	9,500
14	8,100	7,990
16	6,900	6,320
18	5,900	5,190
20	5,150	4,370
22	4,590	3,740
24	4,275	3,250
26	3,870	2,850
28	3,520	2,530

A6-829-013598

#LMI operating code. Refer to LMI manual for instructions.

- Capacities do not exceed 85% of tipping loads as determined by test in accordance with SAE J765.
- Capacities appearing above the bold line are based on structural strength and tipping should not be relied upon as a capacity limitation.

NO LOAD STABILITY FOR
ON OUTRIGGERS AND RUBBER CAPACITIES

	No Load Stability Data	Main Boom 30 ft.
Front (No Load)	Min. boom angle (deg.) for indicated length	0
	Max. boom length (ft.) at 0 deg. boom angle	30
360 Deg. (No Load)	Min. boom angle (deg.) for indicated length	0
	Max. boom length (ft.) at 0 deg. boom angle	30

ON RUBBER CAPACITIES

Radius in Feet	#05		#06
	Stationary Capacity Defined Arc (3) Over Front	Stationary Capacity 360 Degree Arc	Pick & Carry Cap. Up to 2.5 MPH Boom Centered (6) Over Front
5	15,000	10,300	15,000
6	13,200	7,310	13,200
8	10,550	4,820	10,550
10	8,720	3,140	8,720
12	7,390	2,390	7,390
14	6,050	1,860	6,050
16	4,790	1,410	4,790
18	3,920	1,150	3,920
20	3,290	930	3,290
22	2,810	790	2,810
24	2,430	650	2,430
26	2,130	510	2,130
28	1,880	400	1,880

A6-829-014767

#LMI operating code. Refer to LMI manual for instructions.

- Capacities are in pounds and do not exceed 75% of tipping loads as determined by test in accordance with SAE J765.
- Capacities are applicable to machines equipped with 10.00 x 15 (16 ply) tires, at 120 psi cold inflation pressure for static and creep capacities (115 psi for 2.5 mph capacities).
- Defined Arc - Over front includes 6° on either side of longitudinal centerline of machine.
- Capacities are applicable only with machine on firm level surface.
- All rubber lifting depends on proper tire inflation, capacity and condition. Capacities must be reduced for lower tire inflation pressures. Damaged tires are hazardous to safe operation of crane.
- For pick and carry operation, the boom, using the shortest practical boom length, must be centered over front of machine. When handling loads in the structural range with capacities close to maximum ratings, travel should be reduced to creep speed* 2.5 MPH capacities are permissible on main boom only, NOT on boom extension.

*Creep - not over 200 ft. of movement in any 30 minute period and not exceeding 1 mph.

10 FT. - 15 FT. TELE. BOOM EXTENSION
 RATED LIFTING CAPACITIES IN POUNDS
 ON OUTRIGGERS FULLY EXTENDED - 360°

Radius in Feet	360 Degrees				Over Front			
	*10 ft. Tele. Ext.		15 ft. Tele. Ext.		*10 ft. Tele. Ext.		15 ft. Tele. Ext.	
	#21	#24	#31	#34	#21	#24	#31	#34
	0°	45°	0°	45°	0°	45°	0°	45°
8	7,000				7,000			
10	6,500		4,150		6,500		4,150	
12	6,000		3,800		6,000		3,800	
14	5,500	4,500	3,400		5,500	4,500	3,400	
16	5,000	4,200	3,150		5,000	4,200	3,150	
18	4,500	3,900	2,950	2,600	4,500	3,900	2,950	2,600
20	4,200	3,600	2,800	2,550	4,200	3,600	2,800	2,550
22	3,700	3,350	2,650	2,500	3,700	3,350	2,650	2,500
24	3,310	3,150	2,550	2,450	3,500	3,150	2,550	2,450
26	2,850	2,850	2,500	2,400	3,250	3,000	2,500	2,400
28	2,480	2,480	2,450	2,250	3,000	2,850	2,450	2,250
30	2,170	2,170	2,350	2,100	2,800	2,700	2,350	2,100
32	1,900		2,110	2,050	2,600		2,200	2,050
34	1,670		1,880	1,880	2,450		2,000	1,950
36	1,470		1,690		2,300		1,900	
38	1,300		1,510		2,200		1,800	
40			1,360				1,700	
42			1,220				1,600	

A6-829-012513

#LMI operating codes. Refer to LMI manual for instructions

*10 ft. capacities applicable to both the 10 ft. fixed and 10 ft. tele. boom extension.

BOOM EXTENSION CAPACITY NOTES:

1. All capacities above the bold line are based on structural strength of boom extension and do not exceed 85% of tipping loads on outriggers in accordance with J765.
2. 10 ft. and 15 ft. boom extension lengths may be used for double or single line lifting service.
3. Rated load is based on radius, regardless of main boom length.
4. WARNING: Operation of this machine with heavier loads than the capacities listed is strictly prohibited. Machine tipping with boom extension occurs rapidly and without advance warning.
5. For all boom extension lifting service, links must be in place and upper rear pin in boom extension mounting bracket must be removed.
6. Capacities listed are with fully extended outriggers only.
7. No load stability on outriggers 360° with 10 ft. - 15 ft. tele. extension installed:
 - a. Minimum boom angle for 30 ft. main boom = 0°
 - b. Maximum main boom length at 0° main boom angle = 30 ft.
8. When lifting loads the minimum allowable boom angle is: 3° with 0° offset and 48° with 45° offset.

**RATED LIFTING CAPACITIES IN POUNDS ON RUBBER
10 FT. - 15 FT. TELE. BOOM EXTENSION - STATIONARY CAPACITY**

Radius in Feet	360 Degrees				**Defined Arc (3) Over Front			
	*10 ft. Tele. Ext.		15 ft. Tele. Ext.		*10 ft. Tele. Ext.		15 ft. Tele. Ext.	
	#25	#28	#35	#38	#25	#28	#35	#38
	0°	45°	0°	45°	0°	45°	0°	45°
8	5,740				7,000			
10	3,780		4,150		6,500		4,150	
12	2,730		2,930		6,000		3,800	
14	2,080	2,080	2,210		5,500	4,500	3,400	
16	1,630	1,630	1,730		5,000	4,200	3,150	
18	1,310	1,310	1,390	1,390	4,100	3,900	2,950	2,600
20	1,070	1,070	1,130	1,130	3,400	3,400	2,800	2,550
22	880	880	930	930	2,860	2,860	2,650	2,500
24	720	720	770	770	2,450	2,450	2,520	2,450
26	590	590	640	640	2,110	2,110	2,200	2,200
28	490	490	530	530	1,830	1,830	1,940	1,940
30					1,600	1,600	1,720	1,720
32					1,400		1,530	1,530
34					1,230		1,370	1,370
36					1,080		1,230	
38					950		1,110	
40							1,000	
42							900	

#LMI operating codes. Refer to LMI manual for instructions

A6-829-012539B

*10 ft. capacities applicable to both the 10 ft. fixed and 10 ft. tele. boom extension.

**Refer to rubber capacity notes on page 3.

BOOM EXTENSION CAPACITY NOTES:

1. All capacities above the bold line are based on structural strength of boom extension and do not exceed 75% of tipping loads on rubber in accordance with J765.
2. 10 ft. and 15 ft. boom extension lengths may be used for double or single line lifting service.
3. Rated load is based on radius, regardless of main boom length.
4. **WARNING:** Operation of this machine with heavier loads than the capacities listed is strictly prohibited. Machine tipping with boom extension occurs rapidly and without advance warning.
5. For all boom extension lifting service, links must be in place and upper rear pin in boom extension mounting bracket must be removed.
6. No load stability on rubber **over front** with 10 ft. - 15 ft. tele. extension installed:
 - a. Minimum boom angle for 30 ft. main boom = 0°
 - b. Maximum main boom length at 0° main boom angle = 30 ft.
 No load stability on rubber **360°** with 10 ft. - 15 ft. tele. extension installed:
 - a. Minimum boom angle for 30 ft. main boom = 45° with 10' fixed or 10' tele., and 49° with 15' tele. ext.
 - b. Maximum main boom length at 0° main boom angle = 19 ft. with 10' fixed or 10' tele., and 15 ft. with 15' tele. ext.

WORKING RANGE DIAGRAM
(BOOM DEFLECTION NOT SHOWN) D6-829-012579

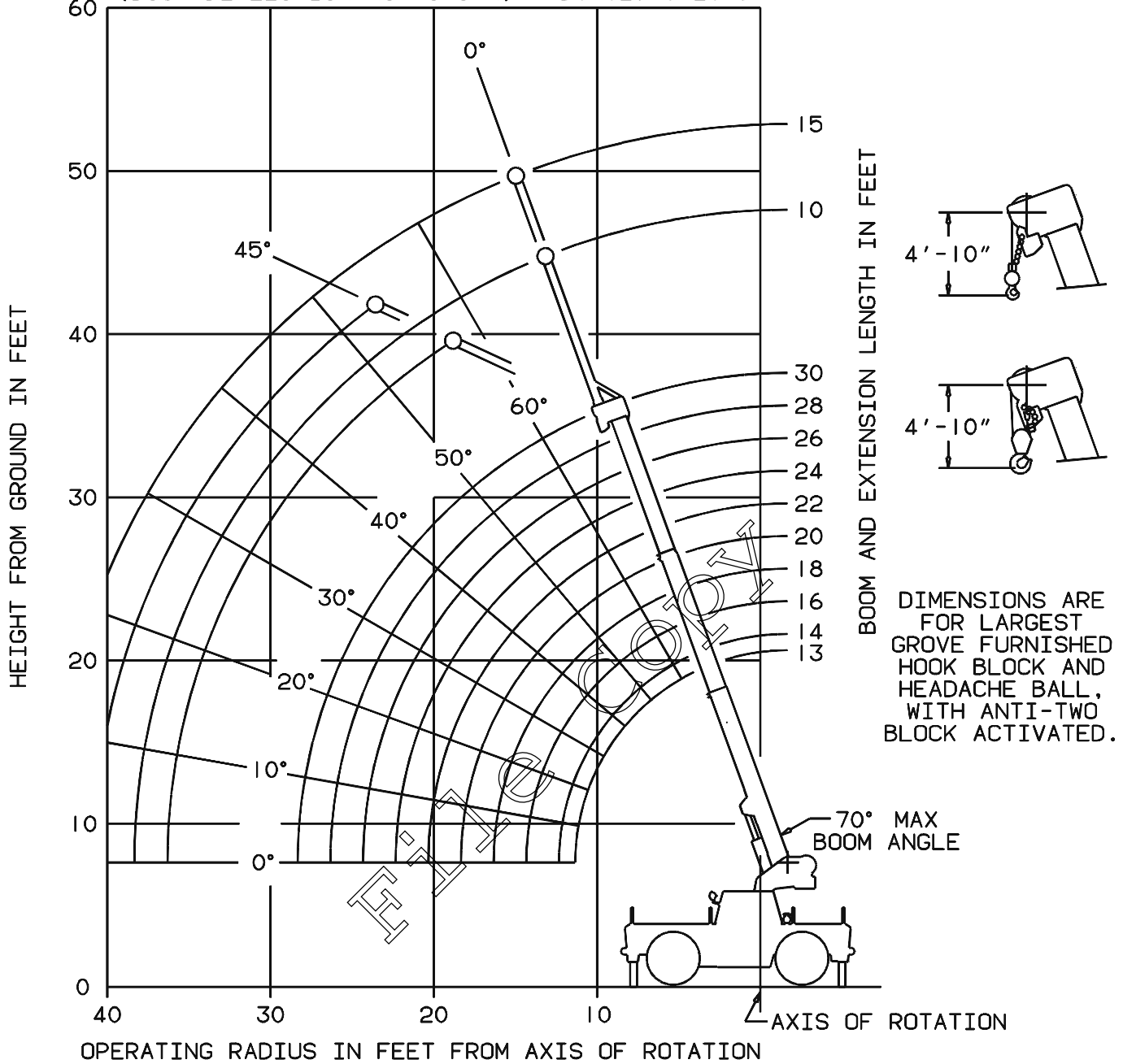

WEIGHT REDUCTIONS FOR LOAD HANDLING DEVICES

10 FT. FIXED BOOM EXTENSION WITH 13 FT. - 30 FT. BOOM	
*Stowed -	153 lbs.
*Erected -	718 lbs.
10 - 15 FT. TELE. BOOM EXTENSION WITH 13 FT. - 30 FT. BOOM	
*Stowed -	196 lbs.
*Erected (Retracted) -	1,057 lbs.
*Erected (Extended) -	1,324 lbs.

*Reduction of main boom capacities

SEARCHER HOOK	55 lbs.
HOOKBLOCKS and HEADACHE BALLS:	
11 Ton, 1 Sheave	304 lbs.+
11 Ton, 2 Sheave	314 lbs.+
5 Ton Headache Ball	172 lbs.+

+Refer to rating plate for actual weight.

When lifting over swingaway and/or jib combinations, deduct total weight of all load handling devices reeved over main boom nose directly from swingaway or jib capacity.

NOTE: All load handling devices and boom attachments are considered part of the load and suitable allowances MUST BE MADE for their combined weights. Weights are for Grove furnished equipment.

6-829-007918

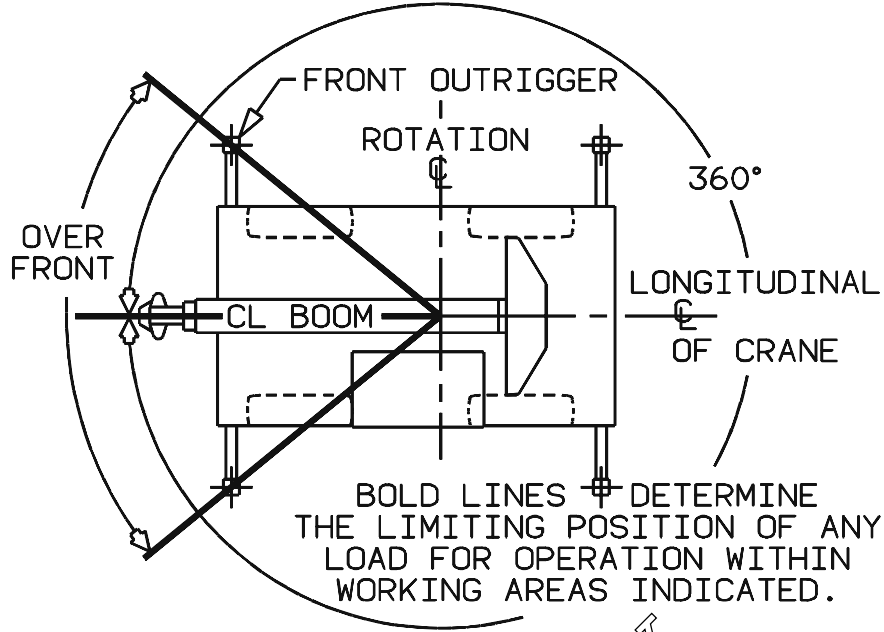

LIFTING ON OUTRIGGERS

COPY

6-829-007917

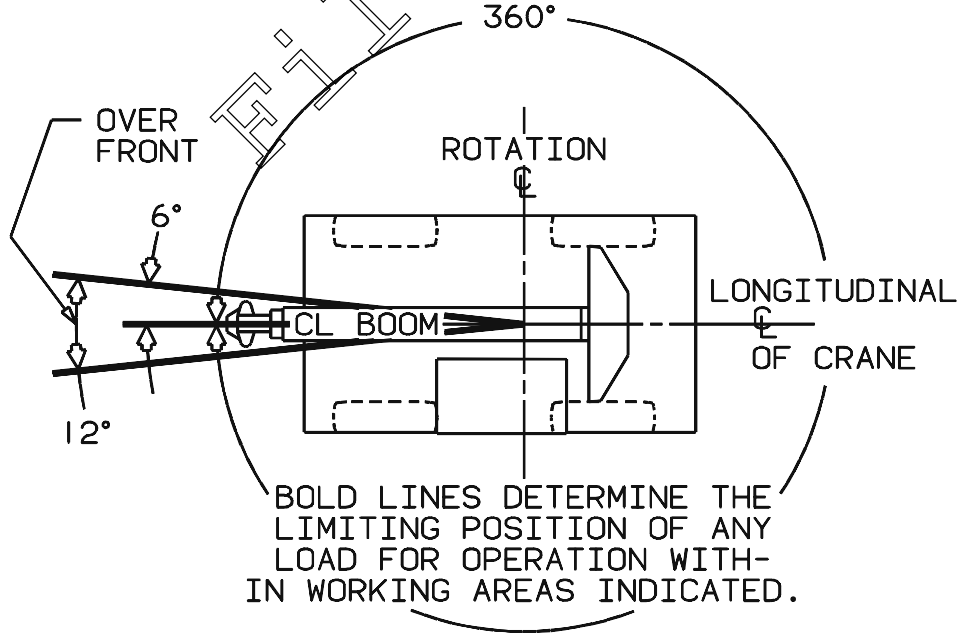

LIFTING ON RUBBER

LOAD DISTRIBUTION CHART FOR CARRY DECK

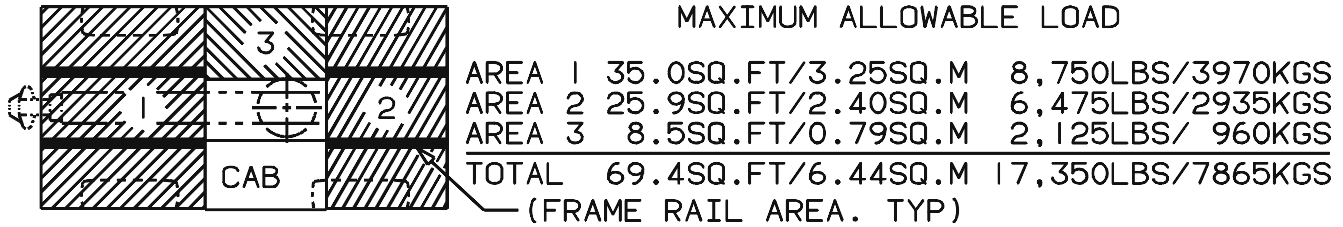

1. MAXIMUM TRAVEL SPEED WITH ANY OR ALL LOADS---2.5 MPH./4 KPH.
2. LOADS TO BE TRANSPORTED ON SMOOTH LEVEL FIRM SURFACES ONLY.
3. BOOM MUST BE RETRACTED AND IN CENTER FORWARD POSITION.
4. ANY COMBINATION OR TOTAL OF AREAS 1,2,& 3 MAY BE USED.
5. LIFTING IS NOT PERMITTED WHEN CARRY DECK IS LOADED EXCEPT FOR LOADING AND UNLOADING CARRY DECK.
6. RATED PICK AND CARRY LOADS MAY BE TRANSPORTED ON DECK AREAS 1 AND 2 PROVIDED THE LOAD IS CRIBBED DIRECTLY ON THE FRAME RAILS.

LINE PULLS AND REEVING INFORMATION

HOISTS	CABLE SPECS	PERMISSIBLE LINE PULLS
Main Model HO-12	9/16" (14 mm) 18x19 Class or 35x7 Rotation Resistant Min. Breaking Str. 37,000 lbs.	7,400 lbs.
Main Model HO-12	9/16" (14 mm) 6x37 Class EIPS, WRC Special Flexible Min. Breaking Str. 33,600 lbs.	7,400 lbs.
Main Model HO-12	12 mm 40x7 Class Rotation Resistant Min. Breaking Str. 28,460 lbs.	5,692 lbs.

The approximate weight of 9/16" rope is 0.7 lb./ft.

SEARCHER HOOK INFORMATION

The LMI controlling code for Searcher Hook usage is **#07** for main boom on outriggers and **#08** for main boom on rubber. Searcher Hook Maximum Capacity is 3,000 lbs. Do not exceed Searcher Hook capacity or given stability capacities on outriggers or on rubber. The use of the searcher hook is to be limited to freely suspended vertical lifts only. The main boom angle is not to exceed 25° from horizontal.

TIRE INFLATION - PSI (BAR)

SIZE (FRONT & REAR)	LOAD RANGE	TRA CODE	LIFTING SERVICE		TRAVEL
			CREEP & STATIC	2.5 MPH (4.0 km/h)	
10.00 x 15 AND 36 x 11 -15	H(16)	—	120 (8.3)	115 (7.9)	115 (7.9)

COPY

FILE